

TS-02

Digital Temperature Sender

Exclusive accessory for GCU-3000 Genset Control Unit

Features

- Accuracy -25°C to +100°C +/-2.0°C (Max.)
- Operating temperature range -55°C to +125°C
- Display accuracy 0.5°C / step
- ESD protection 2000V
- Transmission distance 30M
- Waterproof integral electrical connector
- Exceptional shake and vibration tolerance
- No adjustment needed, 100% compatibility if new sender replaced
- Built in digital sender, excellent accuracy, more precise than the traditional thermocouple or resistance temperature sender
- Extremely stable linearity output, no need for adjustment after installation or maintenance



Specifications

Supply Voltage	3.0 – 5.5 Vdc	Output Interface	SMBus Interface
Supply Current	1.0 mA	Thread	M16-1.5
Accuracy	-25 to +100 °C +/-2.0 °C (Max.)	Ingress Protection	IP65
Display Accuracy	0.5°C / step	Operation Temperature	-55 to +125 °C
Burst Temperature	260°C (10 seconds)	Weight	50 g +/-2%
ESD Protection	2000V		0.11 lb +/-2%

Available cable lengths for TS-02

HU-2500	2.5M Cable, sending temperature parameters to Kutai Genset Control Unit.
HU-5000	5.0M Cable, sending temperature parameters to Kutai Genset Control Unit.

Dimensions

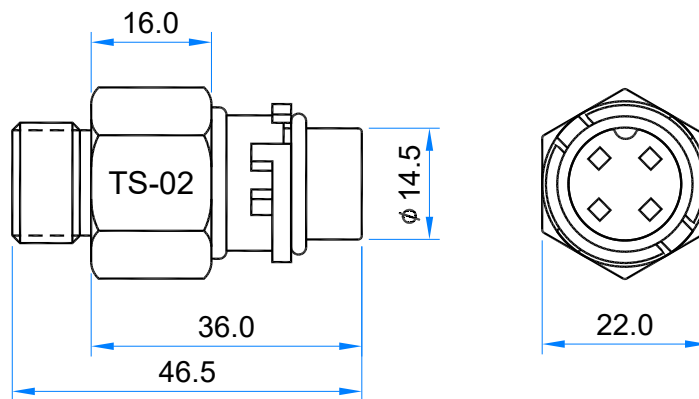

Unit : mm

